



INTELECTRA CARGOBIKE XL

E-Cargobike of DYNAMIC DRIVES GIESSEN



No driver's license, no taxes, no traffic jams, parking right on your doorstep. With our maneuverable cargo bikes, everyone can reach their destination according to e-bike standards - whether on the road or the cycle path.



With our sophisticated modular platform and Plug&Play system, changing tires, wheels and engines is quick and easy. The individual components can be replaced and reused in just a few simple steps.

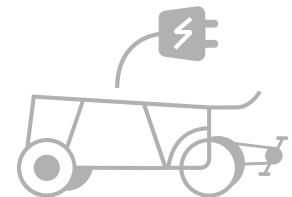

The INTELECTRA Cargobike is developed for a wide range of applications in urban areas. All components of our modern, virtually maintenance-free serial hybrid drive system (iSHS) are optimized for use in multi-track vehicles.

CORE DATA

Legal classification	E-Bike Standards (Pedelec, S-Pedelec)
Vehicle dimensions (Cargo XL)	L: 3128 mm; B: 976 mm; H: 1064 mm
Interior dimensions, Loading area	L: 1628 mm; B: 610 mm; H Aluframe: 567,5 mm
Vehicle weight	133 kg (Unloaded weight, without akku)
Seat height ①	630 mm
Wheelbase ②	2025 mm
Colors	Urban Black, Glow Red, Dynamic Pastel Blue, Active Yellow, City Silk Grey
Applications	E-Cargobike, E-pedelec, person transport, B2B service, delivery & courier services, logistics (last-mile), small business and trade, craft and service, fleet vehicle, and more.

GENERAL TECHNICAL SPECS

Nominal power	2,4 kW
Maintenance-free	30.000 km
Access to vehicle	RFID-Chip
Pedal assistance	up to 25 km/h
Starting aid	up to 6 km/h
Payload	400 kg (incl. tare weight of the driving person)
Motor	2 x 125 W nominal support power
Akku/ Battery	Use of exchangeable 1,400 Wh batteries, optional second battery

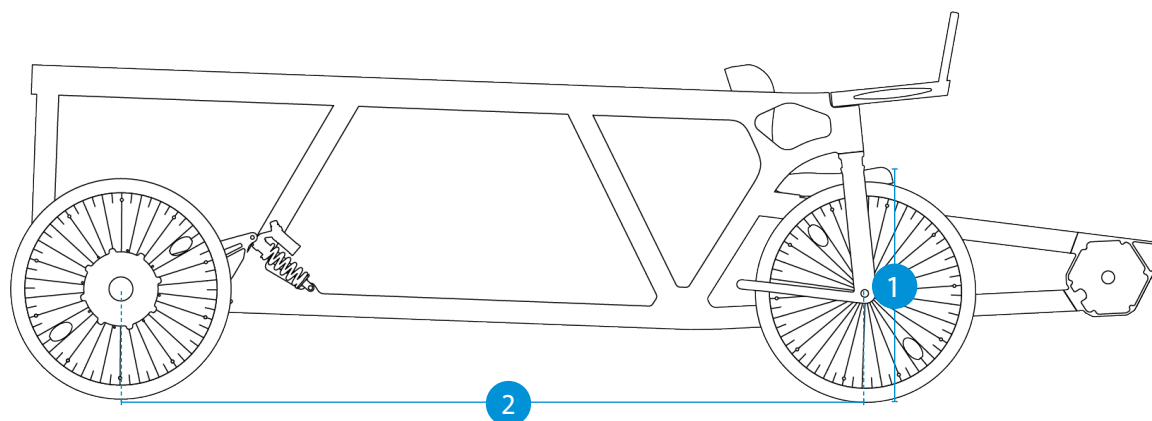

4 WHEELER CARGOBIKE

INTELECTRIC SHS COMPONENTS

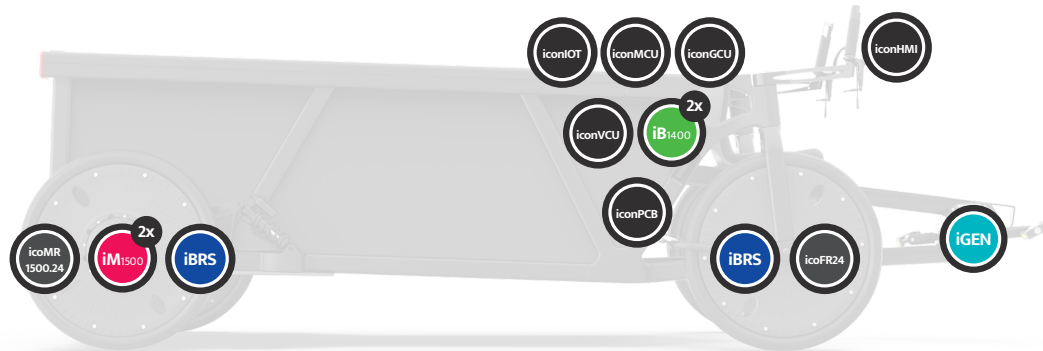

Motor iM1500

1.500 W
190 Nm (peak)



Battery iB1400

1.440 Wh
AES Superpack*



Generator iGEN

250 W
ISIS



Brake system iBRS

203 front brake disk
220 rear brake disk
4 piston brake
HALL sensor brake lever



Control systems iCON

iconVCU
iconGCU
iconMCU
iconPCB
iconIOT
iconHMI



Rims 24 inch

icoFR24
icoMR1500.24

* Das AES SuperPack kann als Miet- oder Kaufmodul integriert werden.
Die Vermietung und Wartung erfolgt über Swobbee GmbH. www.swobbee.de

Technische Änderungen und Irrtümer vorbehalten | Technical changes and errors excepted.

Stand der Information 13.11.2024 | current information of 13.11.2024



FOR MORE INFORMATION CONTACT US.

> mail@dynamic-drives-giessen.com

> www.dynamic-drives-giessen.com

